

Info sheet No.	VL IS 04	Date of revision	7/2/2019
Type	VL 504 – VL 507 (all modifications) VL 601 – VL 607 (all modifications)	Form (Pairing)	DOUBLE / “S” or “Z” WELDED

BOTTOM

TOP

Parameter Označení	Description Popis	Param. value Hodnota (mm)	Tolerances (+/-) Tolerance (+/-)
g	<i>Distance from both sides of sheetpile and weld start (top and bottom welded on both sides, welds between them only one side welds)</i>	100	+50/-100 mm
	<i>Vzdálenost mezi horní hranou štětovnice a začátkem svaru (svary na koncích štětovnic oboustranné, svary po délce štětovnice jen jednostranné)</i>		
h	<i>Distance / spacing between welds</i>	1000	+0/-100 mm
	<i>Vzdálenost / rozteč mezi svary</i>		
i	<i>Dimension / weld length</i>	40	+15/-0 mm
	<i>Rozměr / délka svaru</i>		
f	<i>Top edge alignment</i>	0	+20/-0 mm
	<i>Zarovnání horní hrany</i>		

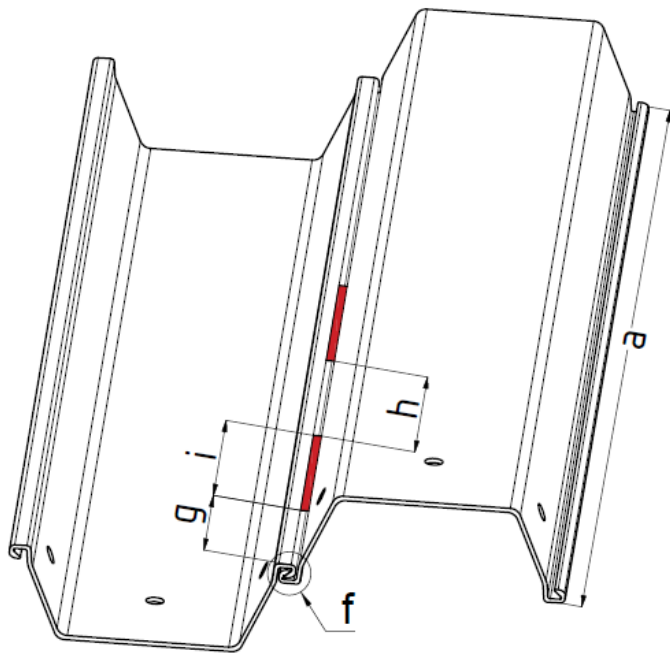
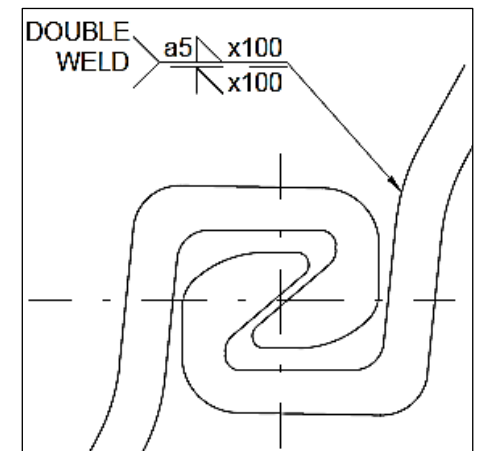
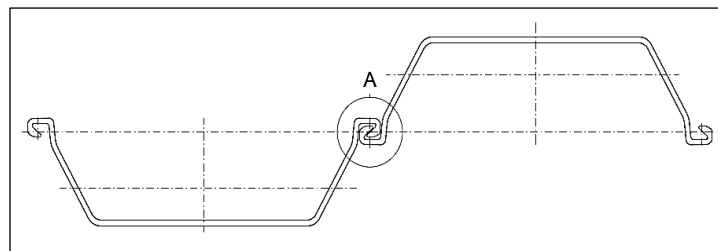

Welders qualified acc. to	EN ISO 5817; EN ISO 14732; EN ISO 9606-1
Welding procedure spec. acc. to	EN ISO 15609-1; EN ISO 15614-1
Requirements for welding supervisory staff	EN ISO 14731