

| | | | |
|----------------|--|------------------|-------------------------------|
| Info sheet No. | VL IS 04 | Date of revision | 17/6/2020 |
| Type | VL 504 – VL 507 (all modifications) VL 601 – VL 607 (all modifications) | Form (Pairing) | DOUBLE / “S” or “Z” WELDED |

BOTTOM

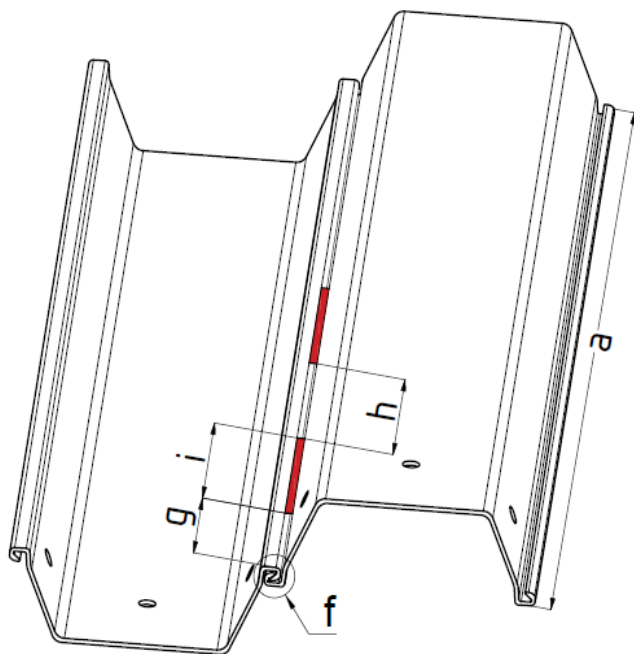

| Parameter Označení | Description Popis | Param. value Hodnota (mm) | Tolerances (+/-) Tolerance (+/-) |
|-----------------------|--|------------------------------|-------------------------------------|
| g | Distance from both sides of sheetpile and weld start (top and bottom welded on both sides, welds between them only one side welds) Vzdálenost mezi horní hranou štětovnice a začátkem svaru (svary na koncích štětovnic oboustranné, svary po délce štětovnice jen jednostranné) | 100 | +50/-100 mm |
| | | | |
| h | Distance / spacing between welds Vzdálenost / rozteč mezi svary | 1000 | +0/-100 mm |
| | | | |
| i | Dimension / weld length Rozměr / délka svaru | 40 | +15/-0 mm |
| | | | |
| f | Top edge alignment Zarovnání horní hrany | 0 | +20/-0 mm |
| | | | |

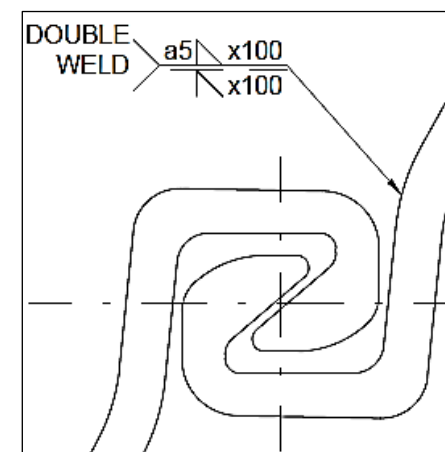
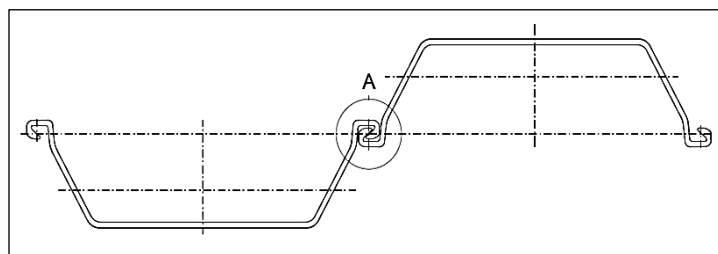

TOP

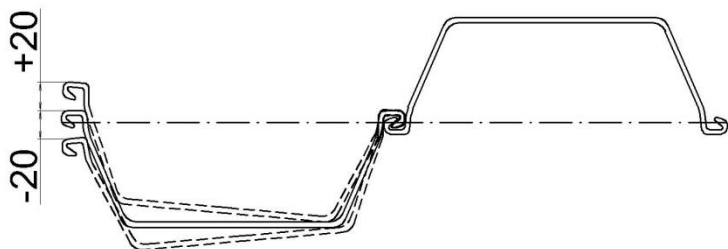

| | |
|--|--|
| Welders qualified acc. to | EN ISO 5817; EN ISO 14732; EN ISO 9606-1 |
| Welding procedure spec. acc. to | EN ISO 15609-1; EN ISO 15614-1 |
| Requirements for welding supervisory staff | EN ISO 14731 |